

©1969 BY AMP INCORPORATED. ALL RIGHTS RESERVED. AMP PRODUCTS COVERED BY PATENTS AND/OR PATENTS PENDING.

THIS PRODUCT DESIGNED AND BUILT BY AMP INCORPORATED. NO LICENSE TO USE THAT DESIGN IN MANUFACTURE, OR TO USE ANY ISSUED OR PENDING PATENTS WHICH ARE INVOLVED, IS IMPLIED.

REVISIONS				
ZONE	LTR	DESCRIPTION	DATE	APPROVED
	A	REV. NOTE 1	LAB 10-15-73	LPA
	B	REVISED	DS 10-13-76	M.S.
	C	REV. PER E.C.N. 8691	AG 3-5-79	M.S.
	D	OBSOLETE - 2 ECN 53622	11-13-86	R.S.
	E	REVISED PER ECN S-3960	4-10-87	R.S.
	F	REV PER OH14-0192-05	1-06	PY
	G	REV PER ECO-12-009412	PY 6-21-12	DE

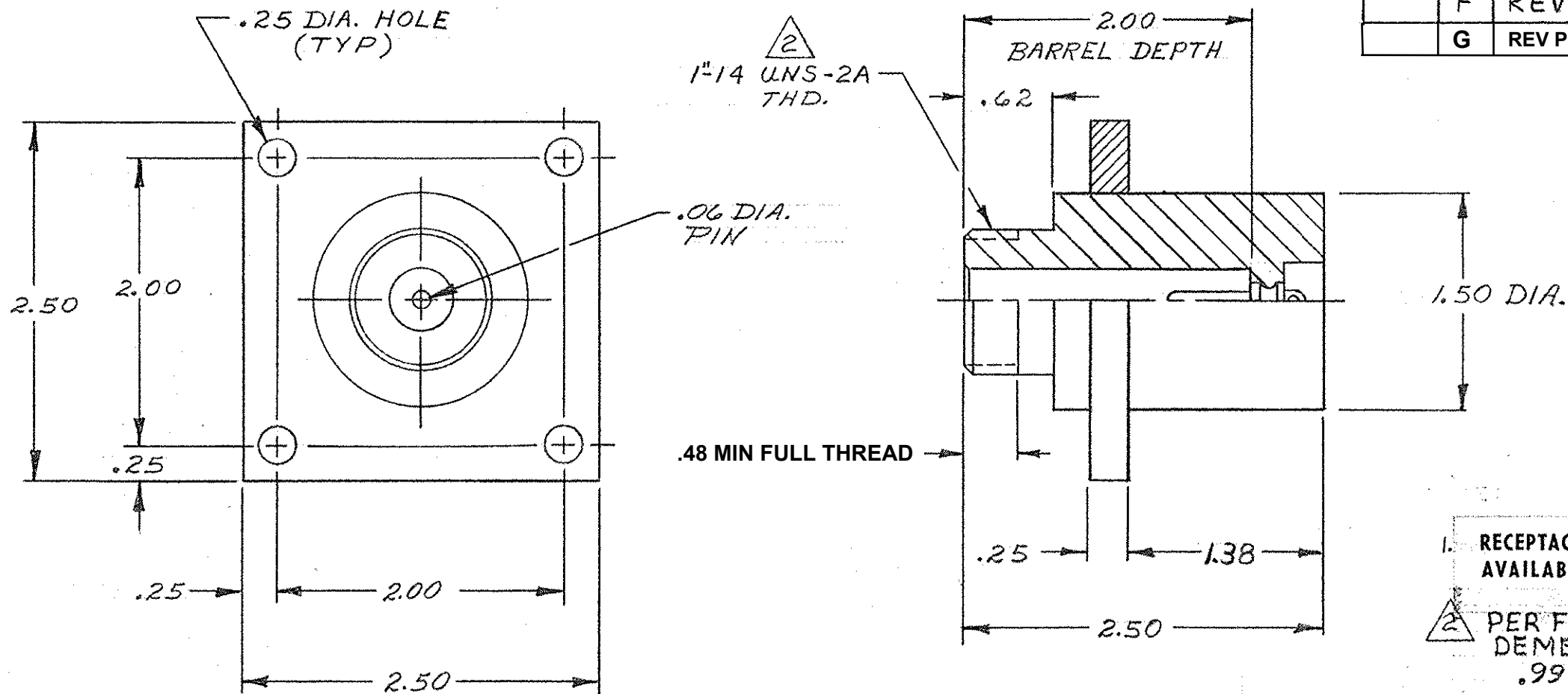

1. RECEPTACLE TO MATE WITH AMP LGH-4 LEAD ASSEMBLY, AVAILABLE SEPARATELY.
 2. PER FEDERAL STANDARD H-28 3 WIRE METHOD. DIMENSION OVER WIRES TO BE: .9975 - 1.0186.

		5-850912-1	AS SHOWN WITH TIN PLATED PIN	
	OBSOLETE	850912-2	AS SHOWN WITH GOLD PLATED PIN	
		850912-1	AS SHOWN WITH TIN-LEAD PLATED PIN	
ITEM NO.	DWG SIZE	PART OR IDENTIFYING NO.	NOMENCLATURE OR DESCRIPTION	SYMBOL

PARTS LIST				
		UNLESS OTHERWISE SPECIFIED: DIMENSIONS ARE IN INCHES TOLERANCES .00 ± .04 ANGLES .000 ± .015	CONTRACT NO. DR <i>L. Witt</i> 6-11-69 CHK APPD APPD DSGN APPD <i>S. Wilson</i> 6-12-69 OTHER APPD	AMP INCORPORATED CAPITRON DIVISION ELIZABETHTOWN, PENNSYLVANIA
		MATERIAL: MOLDED GLASS EPOXY	NAME LGH-4 FLANGED RECEPTACLE ASS'Y RECESSED TERMINAL MOUNT (FOR BULKHEAD APPLICATION)	SIZE B
		FINISH: BLACK	CODE IDENT NO. 00779	NUMBER 850912
		QTY REQD	APPLICATION	REVISION G
				SCALE <i>H</i> WT SHEET 1 OF 1

PRINT DIST L 37